

POPR-I

Landia POPR-I mixers are made from stainless steel. The POPR-I mixers are available with a propeller speed of 150 or 300m, with motor sizes ranging from 1.1 to 30.0 kW. They are also available in Super Duplex (SAF 2507), which is 100% resistant to sea water.

APPLICATION EXAMPLES

- Acidic liquids
- Liquids with a high chloride content, such as at desalination plants
- Anoxic and anaerobic tanks
- SBR reactors
- Sludge tanks
- MBBR reactors
- Fish ensilage



PROPELLER RPM

150 rpm – gear 1:6 or 1:7.25

300 rpm – gear 1:4.5 or 1:5

MATERIAL OF CONSTRUCTION POPR-I 150 RPM

Motor housing and oil chamber	W1.4408/AISI316
Propeller	Stainless steel W1.4301/AISI304 W1.4404/AISI316 (optional)
Protection jacket over gear box	Acid-proof steel W1.4404
Gear	Cast iron EN-GJL-250 (no contact with the liquid)
Gear output shaft	Shaft steel W1.6511/9840 (no contact with the liquid)
Bolts	A4
Exterior sealing system	3 oil sealing rings made of nitrile Wear bush made of stainless steel W1.4301/AISI304 (ceramic coating optional) Wear bush made of steel W1.2363/A2
Interior sealing system	Mechanical shaft seal: silicon carbide/silicon carbide
Oil type	Liquid temperature 0–30 °C SP 100 Liquid temperature 30–60 °C GS 220 GS 220 (with moisture detection)
Grease type	High temperature grease

MATERIAL OF CONSTRUCTION POPR-I 300 RPM

Motor housing and oil chamber	W1.4408/AISI316
Propeller	Stainless steel W1.4301/AISI304 W1.4404/AISI316 (optional)
Protection jacket over gear box	W1.4404/AISI316
Gear	Cast iron EN-GJL-250 (no contact with the liquid)
Gear output shaft	Shaft steel W1.6511/9840 (no contact with the liquid)
Bolts	A4
Exterior sealing system	1 oil sealing ring made of nitrile Wear bush made of stainless steel W1.4301/AISI304 (ceramic coating optional) Mechanical shaft seal: silicon carbide/silicon carbide
Interior sealing system	Mechanical shaft seal: silicon carbide/silicon carbide
Oil type	Liquid temperature 0–30 °C SP 100 Liquid temperature 30–60 °C GS 220 GS 220 (with moisture detection)
Grease type	High temperature grease

SERVICE AND MAINTENANCE

Recommended service interval/oil change	Maximum 4,300 operating hours/minimum once a year
Motor	Lifetime lubricated bearings
Gear	Periodic oil change Calculated service life >100,000 operating hours
Propeller	Periodic grease lubrication

ELECTRICAL CABLE

H07RN-F/S07RN-F EUCAFLEX^{Plus} Cable.

Resistant to oil and UV radiation.



Number of conductors:

H07RN-F 7G1.5 mm² (Not used in United Kingdom)

H07RN-F 7G2.5 mm² (Only United Kingdom. Motor ≤ 5,5 kW)

S07RN-F 7G4+3x1.5 mm²

S07RN-F 7G6+3x1.5 mm²

As standard supplied with 7 m of cable (extra length available upon request).

MONITORING FUNCTIONS

Bimetal thermal sensors 120 °C

Moisture detection system (optional)

ELECTRICAL DATA

Motor type	3-phase AC motor
Nominal voltage	400 V
Minimum voltage allowed	360 V
Nominal frequency	50 Hz
Applicable for VFD operation	Yes
Ingress protection rating	IP 68
Insulation class	F
ATEX classification	Not possible

Model	Nominal power	Motor	Full load current (400 V)	Connection method	Start current (DOL)	cos phi	Efficiency
	[kW]	[rpm]	[A]	Y/Δ	[A]		[%]
POPR-I 4.0/3.0 kW-150 rpm	4.0	965	8.5	Δ	43	0.79	85.5
POPR-I 7.5/4.0 kW-150 rpm	7.5	970	15.5	Δ	91	0.79	87.5
POPR-I 4.0 kW-300 rpm	4.0	1,435	8.8	Δ	61	0.78	84.1
POPR-I 11.0 kW-300 rpm	11.0	1,455	21.5	Δ	146	0.84	87.9
POPR-I 18.5 kW-300 rpm	18.5	1,460	35.0	Δ	238	0.85	89.3

For voltages others than 400 V/50 Hz please refer to the attached Appendix.

OVERALL DIMENSIONS

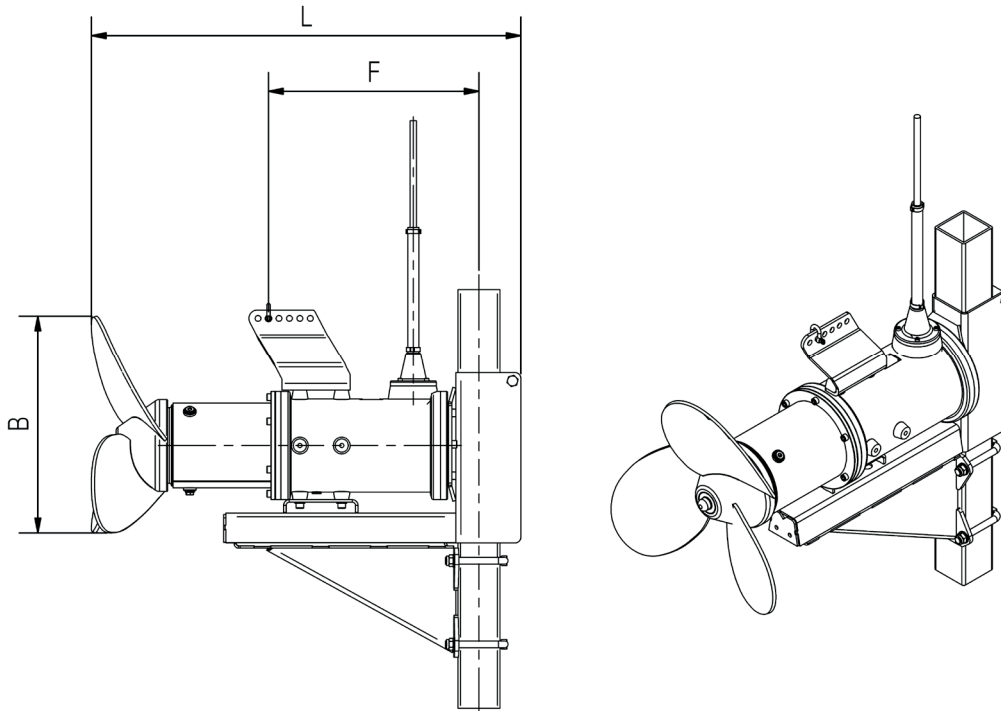

Model	Propeller diameter [mm]	B [mm]	F [mm]	L [mm]	Guide pipe [mm]	Weight [kg]
POPR-I 4.0/3.0 kW-150 rpm	ø730	585	490	1,110	100 × 100	188
POPR-I 4.0/3.0 kW-150 rpm	ø845	685	490	1,110	100 × 100	188
POPR-I 4.0/3.0 kW-150 rpm	ø900	735	490	1,110	100 × 100	188
POPR-I 4.0/3.0 kW-150 rpm	ø930	770	490	1,110	100 × 100	188
POPR-I 7.5/4.0 kW-150 rpm	ø1030	835	530	1,220	100 × 100	259
POPR-I 7.5/4.0 kW-150 rpm	ø1080	905	530	1,220	100 × 100	259
POPR-I 4.0 kW-300 rpm	ø575	470	380	885	80 × 80	119
POPR-I 11.0 kW-300 rpm	ø770	650	475	1,095	100 × 100	194
POPR-I 18.5 kW-300 rpm	ø880	730	485	1,170	100 × 100	242

*200x100 stainless guide pipe

We reserve the right to make technical changes.