

# POP-I

The Landia POP-I 150 is a slow-speed mixer for mixing and flow-making with a low energy consumption. This can, for example, be in aeration tanks or anaerobic tanks at sewage treatment plants.

The Landia POP-I 300 is a flexible and efficient mixer that is typically used for mixing liquids with a high dry matter content, such as dewatered sludge or biomass. The relatively low speed means that the POP-I 300 is the ideal mixer for highly viscose liquids.

## APPLICATION EXAMPLES

POP-I 150/300/400:

- ▶ Aeration tanks
- ▶ Oxydation ditches
- ▶ Anoxic and anaerobic tanks
- ▶ MBBR reactors

POP-I 300:

- ▶ Sludge with a high dry matter content
- ▶ Liquid biomass

## PROPELLER RPM

150 rpm – gear 1:6 or 1:7.25

300 rpm – gear 1:4.5 or 1:5



**MATERIAL OF CONSTRUCTION POP-I 150 RPM**

Motor housing and oil chamber	Cast iron EN-GJL-250
Propeller	Steel W1.0038/S235JR Domex 700 (optional) Stainless steel W1.4301/AISI304 (optional) W1.4404/AISI316 (optional)
Gear	Cast iron EN-GJL-250
Output shaft gear	Shaft steel W1.6511/9840 (no contact with the liquid)
Bolts	A4
Exterior sealing system	3 oil sealing rings made of nitrile Stainless steel wear bush W1.4301/AISI304 (ceramic coating optional) Steel wear bush W1.2363/A2
Interior sealing system	Mechanical shaft seal: silicon carbide/silicon carbide
Oil type	Liquid temperature 0–30 °C SP 100 Liquid temperature 30–60 °C GS 220 GS 220 (with moisture detection)
Grease type	High temperature grease

**MATERIAL OF CONSTRUCTION POP-I 300 RPM**

Motor housing and oil chamber	Cast iron EN-GJL-250
Propeller	Steel W1.0038/S235JR Domex 700 (optional) Stainless steel W1.4301/AISI304 (optional) W1.4404/AISI316 (optional)
Gear	Cast iron EN-GJL-250
Output shaft gear	Shaft steel W1.6511/9840 (no contact with the liquid)
Bolts	A4
Exterior sealing system	1 oil sealing ring made of nitrile Wear bush made of stainless steel W1.4301/AISI304 (ceramic coating optional) Mechanical shaft seal: silicon carbide/silicon carbide
Interior sealing system	Mechanical shaft seal: silicon carbide/silicon carbide
Oil type	Liquid temperature 0–30 °C SP 100 Liquid temperature 30–60 °C GS 220 GS 220 (with moisture detection)
Grease type	High temperature grease

## SERVICE AND MAINTENANCE

Recommended service interval/oil change	Max. 4,300 operating hours/minimum once a year
Motor	Lifetime lubricated bearings
Gear	Periodic oil change Calculated service life >100,000 operating hours
Propeller	Periodic grease lubrication

## SURFACE TREATMENT

Machinery enamel: RAL 9005 (Jet Black)	Jet Black
2-component coating: RAL 7005 (Mouse Grey) (optional)	Mouse Grey

## ELECTRICAL CABLE

H07RN-F/S07RN-F EUCAFLEX<sup>Plus</sup> Cable.

Resistant to oil and UV radiation.

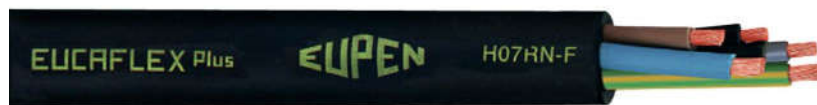

Number of conductors:

H07RN-F 7G1.5 mm<sup>2</sup> (Not used in United Kingdom)

H07RN-F 7G2.5 mm<sup>2</sup> (Only United Kingdom. Motor ≤ 5,5 kW)

S07RN-F 7G4+3x1.5 mm<sup>2</sup>

S07RN-F 7G6+3x1.5 mm<sup>2</sup>

As standard supplied with 7 m of cable (extra length available upon request).

## MONITORING FUNCTIONS

Bimetal thermal sensors 120 °C

Moisture detection system (optional)

**ELECTRICAL DATA**

Motor type	3-phase AC motor
Nominal voltage	400 V
Minimum voltage allowed	360 V
Nominal frequency	50 Hz
Applicable for VFD operation	Yes
Ingress protection rating	IP 68
Insulation class	F
ATEX classification	II 2 G Ex db h IIB T4 Gb (Option, only available for specific models)

Model	Nominal power	Motor	Full load current (400 V)	Connection method	Start current (DOL)	cos phi	Efficiency
	[kW]	[rpm]	[A]	Y/Δ	[A]		[%]
POP-I 1.1/0.75 kW-150 rpm	1.1	955	2.75	Y	15	0.71	78.1
POP-I 3.0/1.1 kW-150 rpm	3.0	955	7.1	Δ	50	0.73	83.3
POP-I 4.0/3.0 kW-150 rpm	4.0	965	8.5	Δ	43	0.79	85.5
POP-I 7.5/4.0 kW-150 rpm	7.5	970	15.5	Δ	91	0.79	87.5
POP-I 2.2 kW-300 rpm	2.2	1,410	5.0	Y	30	0.80	80.2
POP-I 4.0 kW-300 rpm	4.0	1,435	8.8	Δ	61	0.78	84.1
POP-I 5.5 kW-300 rpm	5.5	1,440	11.0	Δ	68	0.87	84.6
POP-I 11.0 kW-300 rpm	11.0	1,455	21.5	Δ	146	0.84	87.9
POP-I 18.5 kW-300 rpm	18.5	1,460	35.0	Δ	238	0.85	89.3

For voltages others than 400 V/50 Hz please refer to the attached Appendix.

## OVERALL DIMENSIONS

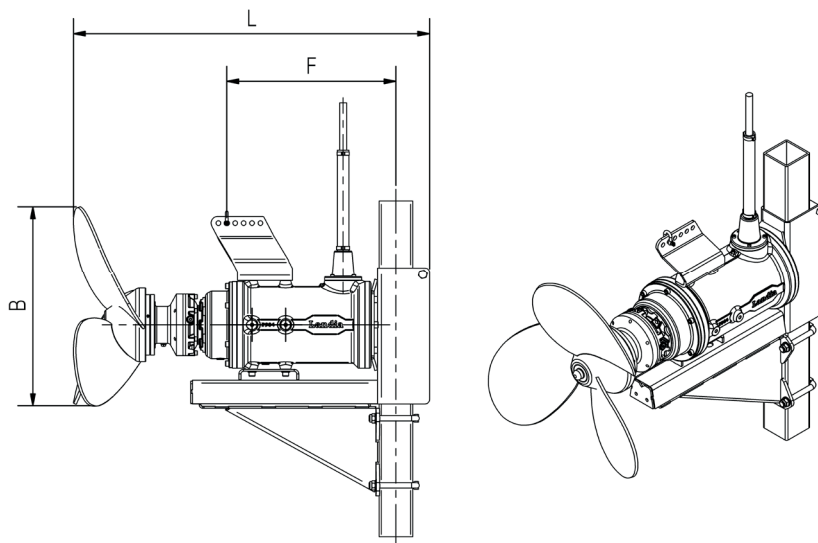

Model	Propeller diameter [mm]	B [mm]	F [mm]	L [mm]	Guide pipe [mm]	Weight [kg]
POP-I 1.1/0.75 kW-150 rpm	ø620	510	400	890	80 × 80	112
POP-I 3.0/1.1 kW-150 rpm	ø730	585	390	990	80 × 80	130
POP-I 3.0/11 kW-150 rpm	ø845	685	390	990	80 × 80	130
POP-I 3.0/1.1 kW-150 rpm	ø900	735	390	990	80 × 80	130
POP-I 4.0/3.0 kW-150 rpm	ø930	770	495	1,110	100 × 100	180
POP-I 7.5/4.0 kW-150 rpm	ø1030	835	530	1,270	100 × 100	250
POP-I 7.5/4.0 kW-150 rpm	ø1150	980	530	1270	100 × 100	250
POP-I 2.2 kW-300 rpm	ø450	375	345	765	80 × 80	74
POP-I 4.0 kW-300 rpm	ø575	470	380	885	80 × 80	99
POP-I 5.5 kW-300 rpm	ø620	510	425	952	80 × 80	112
POP-I 11.0 kW-300 rpm	ø770	650	475	1,095	100 × 100	194
POP-I 18.5 kW-300 rpm	ø880	730	485	1,170	100 × 100	242

\*200x100 stainless guide pipe

We reserve the right to make technical changes.